

STEEL SQUARE TUBE/COLUMN  
(PREPPED PER FIBERTITE GUIDLINES &  
PRIMED W/ FORTI-LOCK METAL PRIMER)

FTR FORTI-LOCK PMMA LIQUID APPLIED  
RESIN BASE COAT

FTR-FORTI-LOCK REINFORCING FLEECE

FTR FORTI-LOCK PMMA LIQUID APPLIED  
RESIN TOP COAT

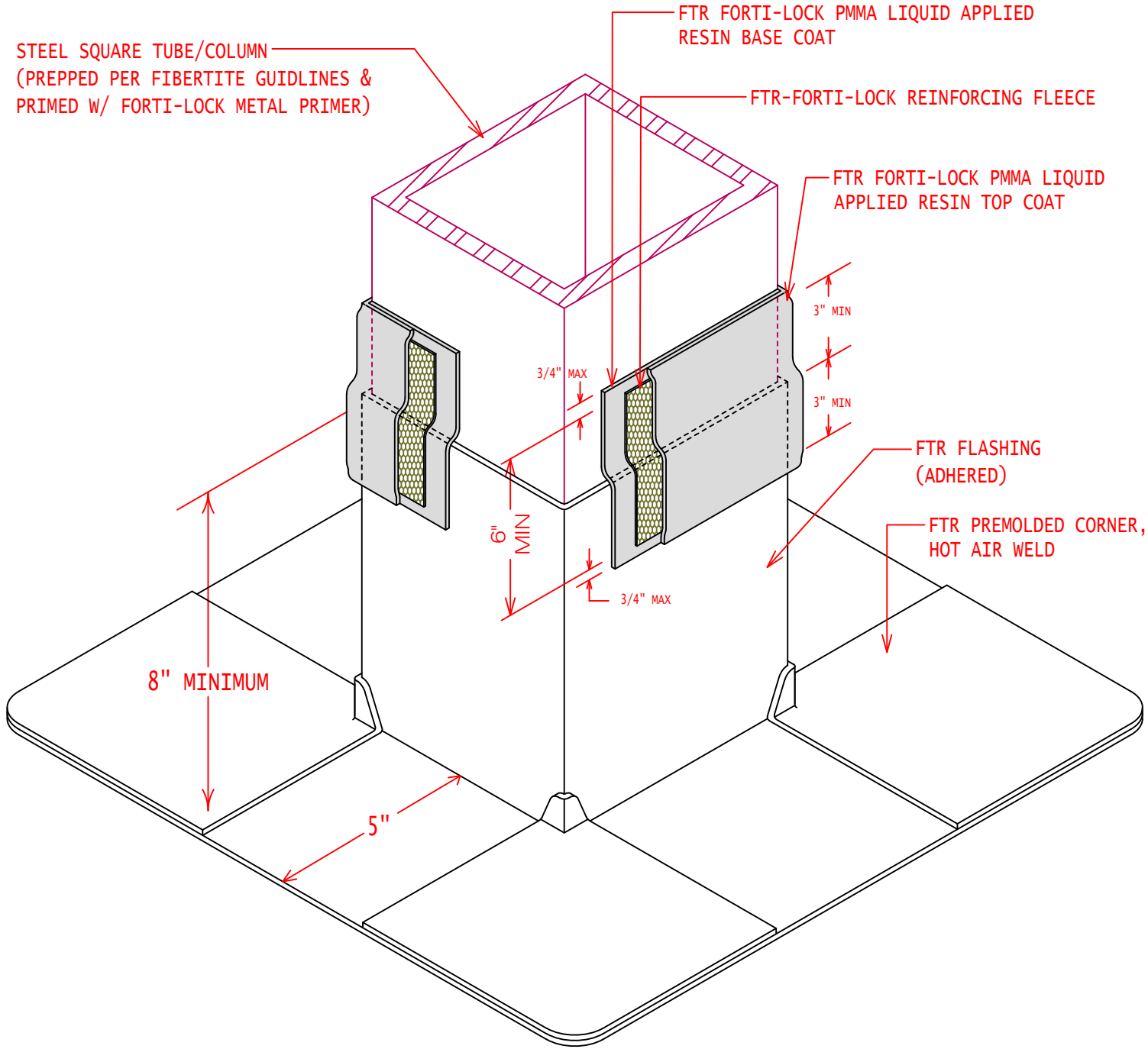

<p>GENERAL REFERENCE: FORTI-LOCK APPLICATION GUIDLINES</p>		<p>SQUARE TUBE/COLUMN FLASHING TERMINATED WITH FTR FORTI-LOCK™ PMMA FLASHING SYSTEM</p>	
<p>APPLICABLE SYSTEMS: PRE APPROVED ONLY</p>		<p>REVISES DETAIL ALL PREVIOUS</p>	<p>ISSUE DATE 09-17-20</p>
		<p>DRAWING NUMBER FTR-FL6</p>	